



Cambridge O Level

BIOLOGY

3172/12

Paper 1 Multiple Choice

May/June 2021

1 hour

You must answer on the multiple choice answer sheet.

You will need: Multiple choice answer sheet
Soft clean eraser
Soft pencil (type B or HB is recommended)

INSTRUCTIONS

- There are **forty** questions on this paper. Answer **all** questions.
- For each question there are four possible answers **A, B, C** and **D**. Choose the **one** you consider correct and record your choice in soft pencil on the multiple choice answer sheet.
- Follow the instructions on the multiple choice answer sheet.
- Write in soft pencil.
- Write your name, centre number and candidate number on the multiple choice answer sheet in the spaces provided unless this has been done for you.
- Do **not** use correction fluid.
- Do **not** write on any bar codes.
- You may use a calculator.

INFORMATION

- The total mark for this paper is 40.
- Each correct answer will score one mark.
- Any rough working should be done on this question paper.

This document has **20** pages. Any blank pages are indicated.



- 1 The diagram shows a cell from a plant leaf and a cell from an animal's skin.

Which part will stain blue-black with iodine solution?

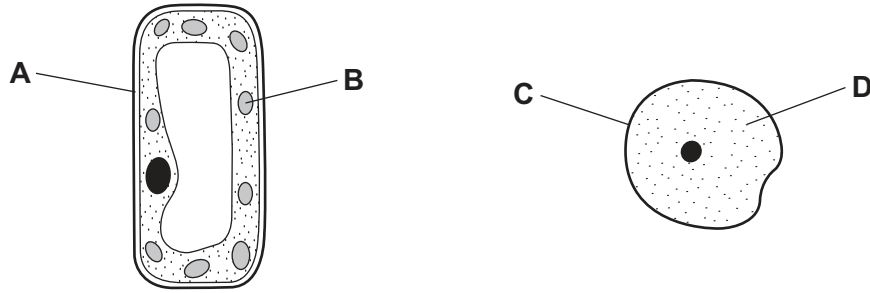

- 2 Which adaptations would make a column of cells suitable for conducting water up a plant stem?

- 1 the large surface area of the cell walls
- 2 the loss of cross walls between cells
- 3 the loss of all cellular contents
- 4 the thickening of cell walls

A 1 and 2 only **B** 1 and 4 only **C** 2, 3 and 4 only **D** 1, 2, 3 and 4

- 3 Discs of raw potato tissue are weighed (initial mass). They are then placed in sucrose solutions of different concentrations. After one hour, their masses are measured again (final mass).

The graph shows how the ratio of initial mass : final mass changes with concentration of sucrose solution.

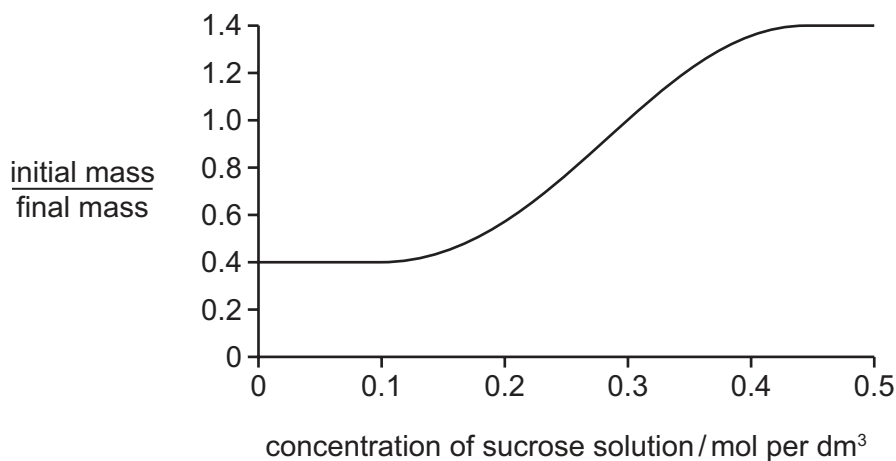

Which concentration of sucrose solution has the same water potential as the cells in the potato discs?

- A** 0.1 mol per dm³
- B** 0.3 mol per dm³
- C** 0.4 mol per dm³
- D** 0.5 mol per dm³

4 Which diagram shows active transport in a root hair cell?

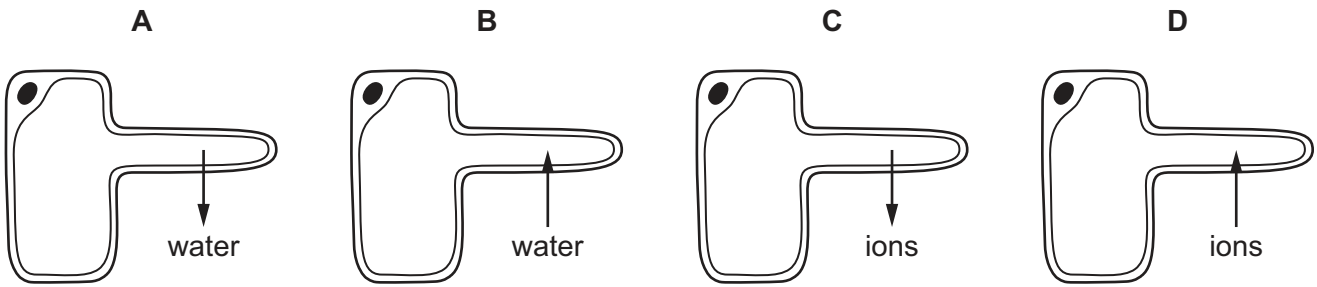

5 Which statement about enzymes is correct?

- A Each enzyme can catalyse many different types of reactions.
- B Enzymes are only found inside living cells.
- C Enzymes are used up when catalysing reactions.
- D Enzymes cannot start reactions but can only speed them up.

6 Which graph shows the rate at which an enzyme reacts with its substrate at different temperatures?

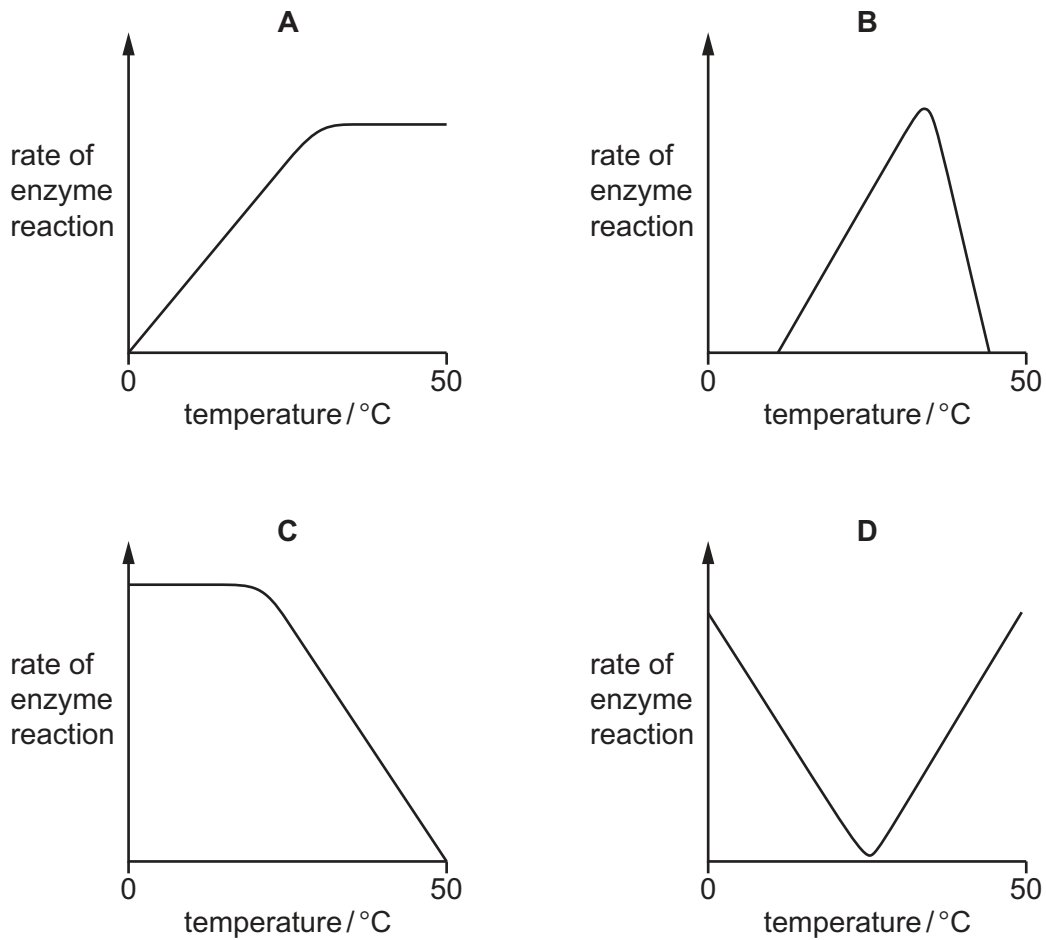

- 7 A plant has leaves that are green in the centre but white around the edges.

Starch is removed from the plant and then one of its leaves is partly covered with black paper on both sides, as shown.

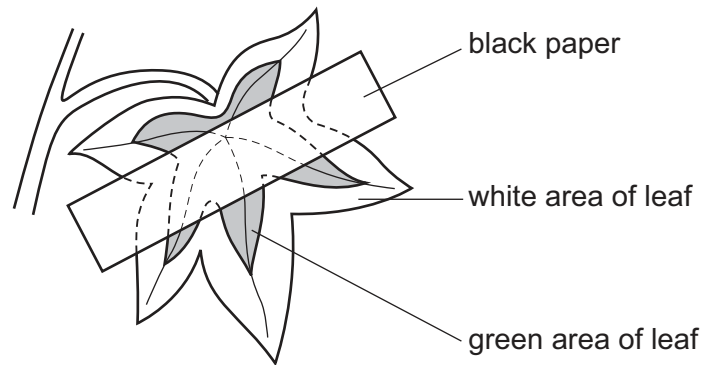

The plant is placed in bright light for 48 hours. The leaf is then tested for starch.

Which diagram shows the colours that are obtained?

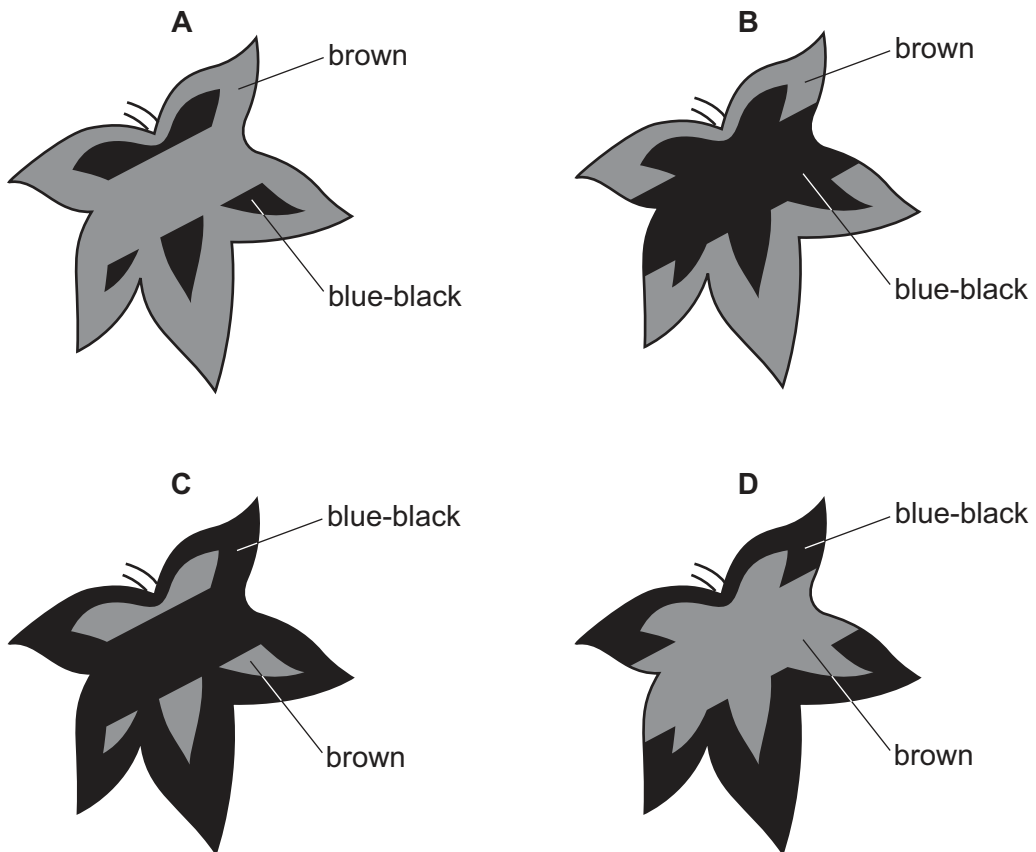

8 What is the use of magnesium ions in plants?

| | needed to make chlorophyll | needed to make proteins | needed for normal growth | |
|----------|----------------------------|-------------------------|--------------------------|--------------------------|
| A | ✓ | x | ✓ | key ✓ = yes x = no |
| B | ✓ | ✓ | x | |
| C | x | ✓ | ✓ | |
| D | x | ✓ | x | |

9 Which cereal should be **avoided** as a regular breakfast for someone suffering from heart disease?

| | cereal | energy /kJ | fat /g | protein /g | carbohydrate /g | fibre /g |
|----------|----------------|------------|--------|------------|-----------------|----------|
| A | Nutty Crunch | 784 | 7.8 | 4.0 | 24 | 2.8 |
| B | Breakfast Bran | 545 | 0.7 | 3.8 | 21 | 6.4 |
| C | Ready Rice | 485 | 0.9 | 2.3 | 23 | 2.3 |
| D | Wheat Brek | 696 | 1.7 | 4.5 | 31 | 4.5 |

- 10 Some palm oil and lipase were placed in a tube made of partially permeable membrane. The tube was tied tightly at both ends and then immersed in a beaker of water at 40 °C, as shown.

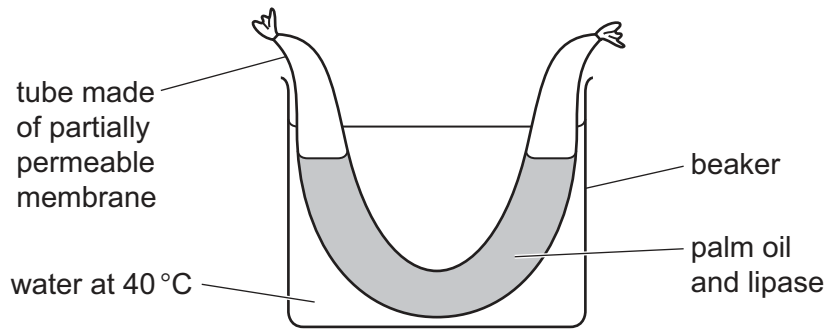

At intervals, samples of water were removed from the beaker and a drop of universal indicator was added to each sample.

The results are shown.

| | | | | | | |
|-----------------------|---|---|-----|-----|-----|-----|
| time / minutes | 0 | 3 | 6 | 9 | 12 | 15 |
| pH of water in beaker | 7 | 7 | 6.8 | 6.6 | 6.3 | 6.1 |

Which statements explaining the results are correct?

- 1 Lipase has digested the fat molecules.
- 2 Lipase molecules have diffused through the membrane into the water in the beaker.
- 3 Fatty acid molecules have diffused through the membrane into the water in the beaker.

A 1, 2 and 3 **B** 1 and 2 only **C** 1 and 3 only **D** 2 and 3 only

- 11 Which chemical change does **not** occur in the liver?

- A** amino acids to glucose
- B** glucose to amino acids
- C** glucose to glycogen
- D** glycogen to glucose

12 The diagram shows a cross-section of a leaf.

From which part does most of the water evaporate during transpiration?

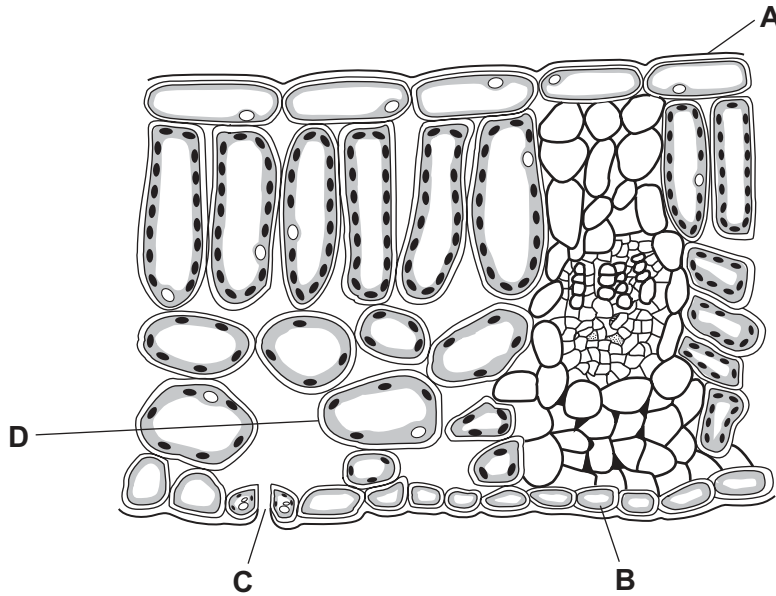

13 The rate of water loss from leaves changes as environmental factors change.

Which graph shows the change in the rate of water loss as the humidity increases?

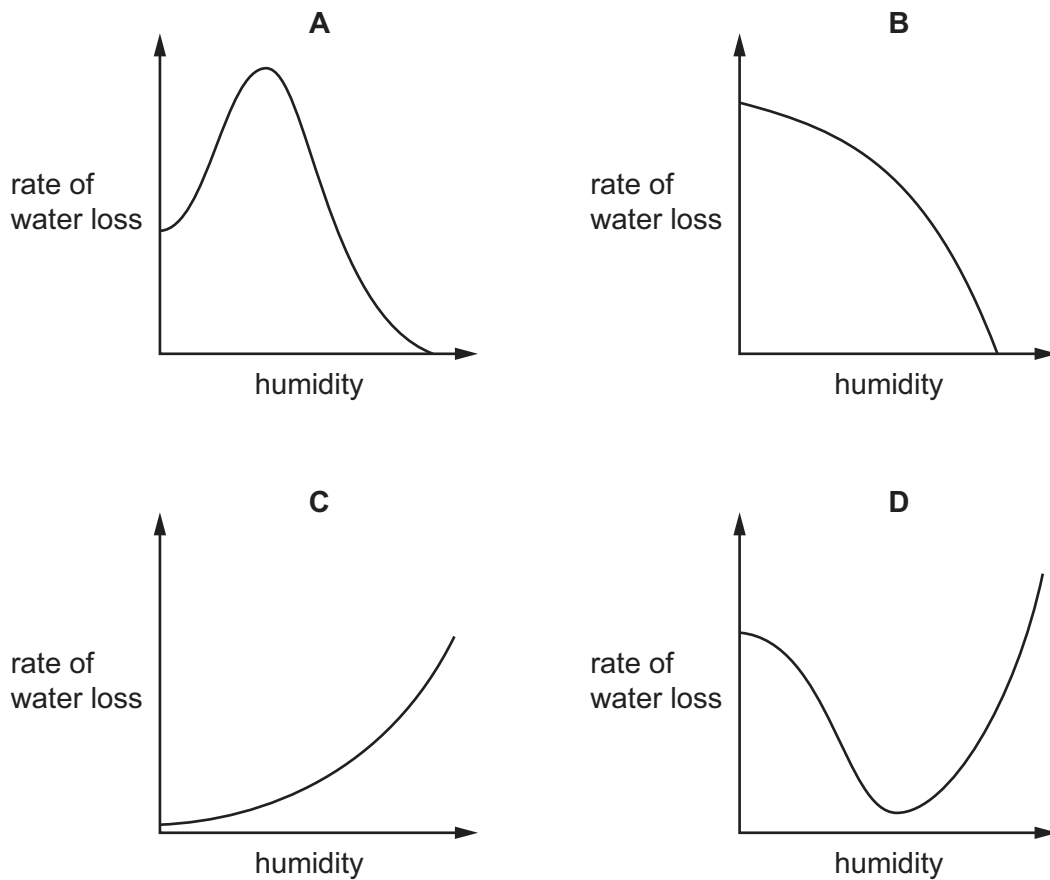

- 14 The graph shows pressure changes in the left atrium and in the left ventricle during one heartbeat.

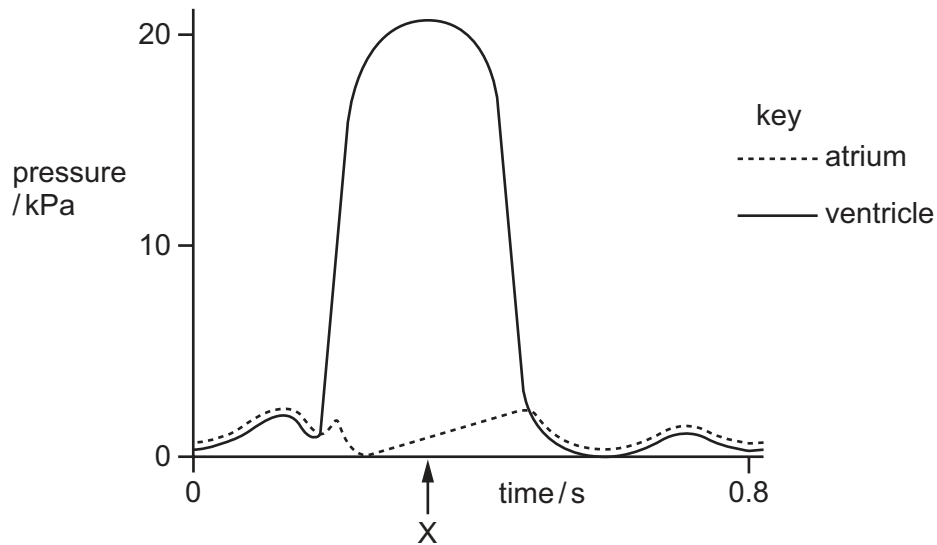

What is the state of the valves in the heart at time X?

| | left atrio-ventricular valve (bicuspid) | semi-lunar valve (in aorta) |
|----------|---|-----------------------------|
| A | closed | closed |
| B | closed | open |
| C | open | closed |
| D | open | open |

- 15 Humans have a double circulatory system for blood.

What is a feature of a double circulatory system?

- A** Blood only flows through one circuit.
B There is a low pressure circulation to the body tissues.
C There is a low pressure circulation to the lungs.
D Valves ensure a two-way flow of blood.
- 16 Which component of the blood is essential for clotting?

- A** plasma
B platelets
C red blood cells
D white blood cells

17 The diagram shows an experiment to study respiration in growing barley seeds.

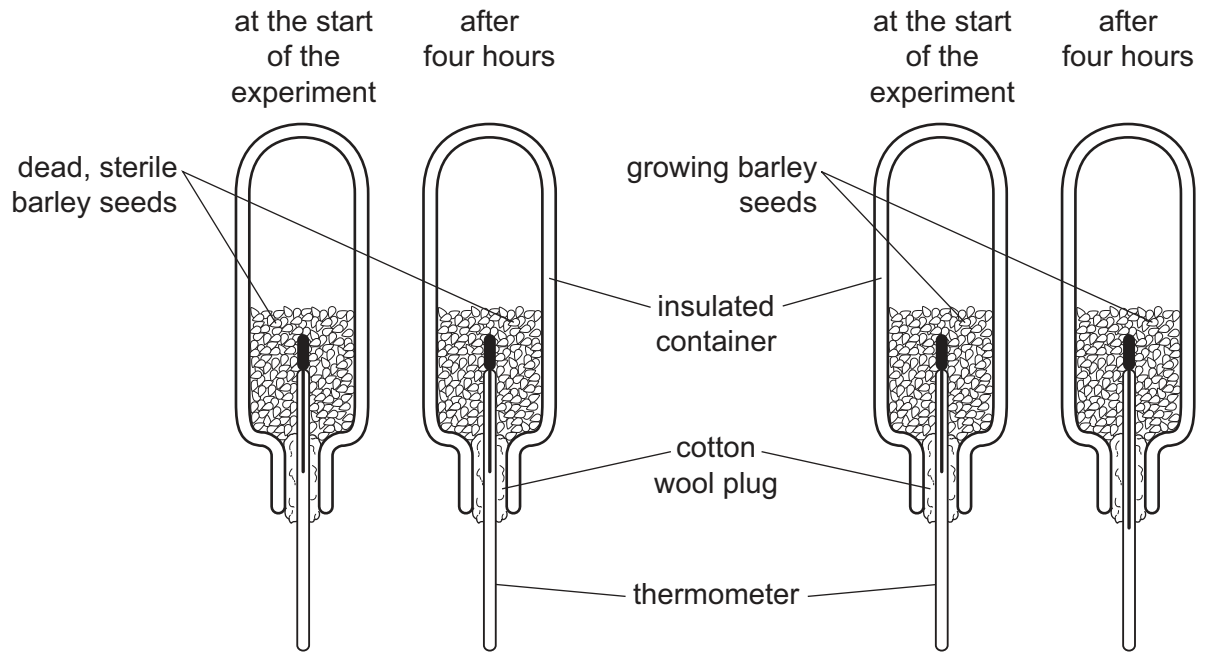

The results of this experiment show that respiration

- A** produces carbon dioxide.
- B** releases energy.
- C** requires glucose.
- D** uses up oxygen.

18 An experiment was set up as shown.

Sodium hydroxide solution absorbs carbon dioxide. Limewater is an indicator which changes from clear to cloudy in the presence of carbon dioxide.

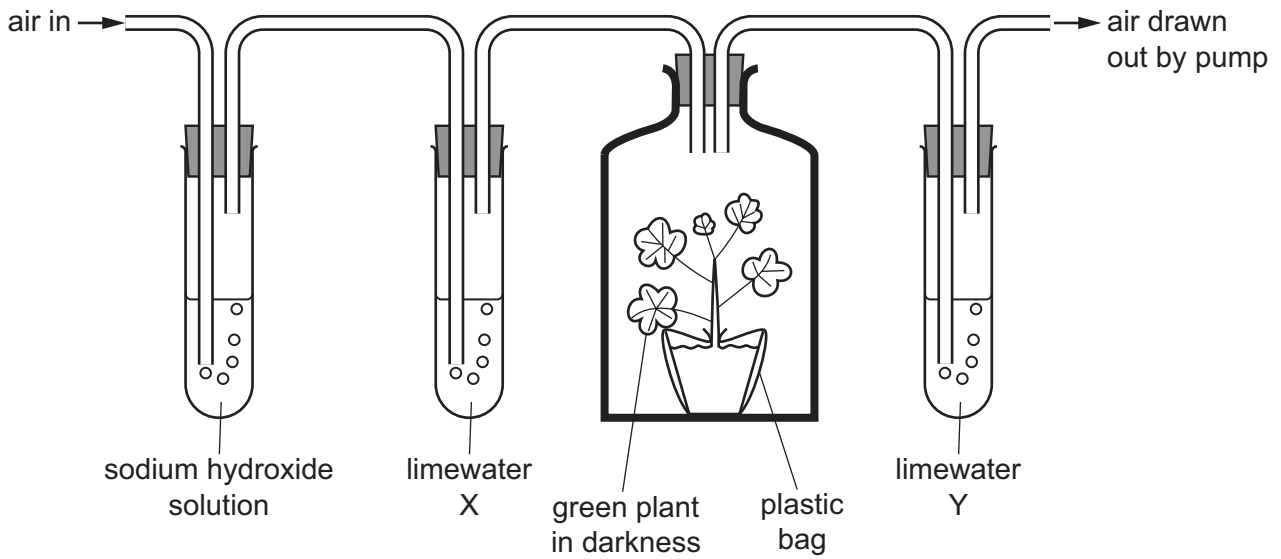

After some time, limewater X was still clear but limewater Y had become cloudy.

Which process has taken place?

- A aerobic respiration
- B anaerobic respiration
- C fermentation
- D photosynthesis

19 Which diagram represents anaerobic respiration in yeast?

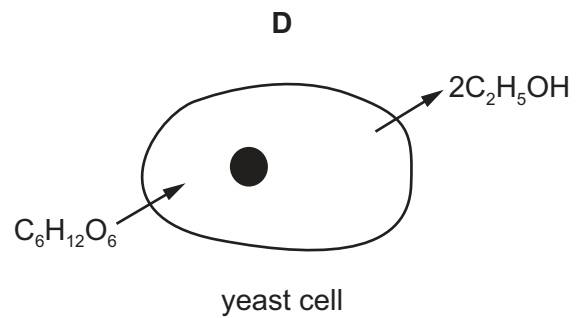
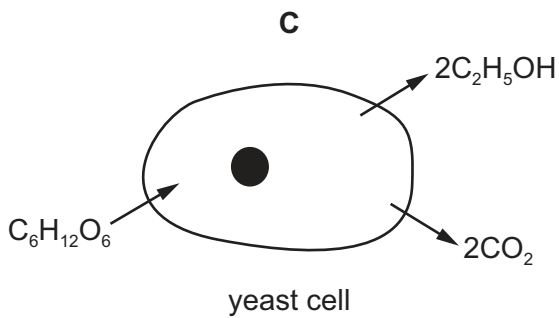
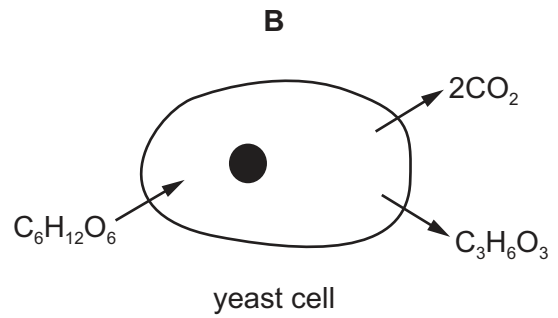
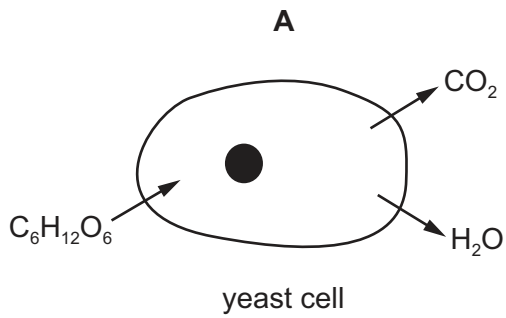

20 The diagram shows a kidney, its blood vessels and the ureter.

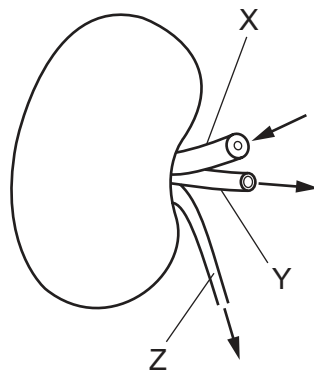

Which statements are correct?

- 1 The blood in vessel Y contains less water than the blood in vessel X.
- 2 The fluid in vessel Z is urine.
- 3 Vessel X is the renal vein.

A 1, 2 and 3 **B** 1 and 2 only **C** 1 and 3 only **D** 2 and 3 only

21 The graphs show how four different conditions in the body may change with time.

In which graph is the condition being controlled by negative feedback?

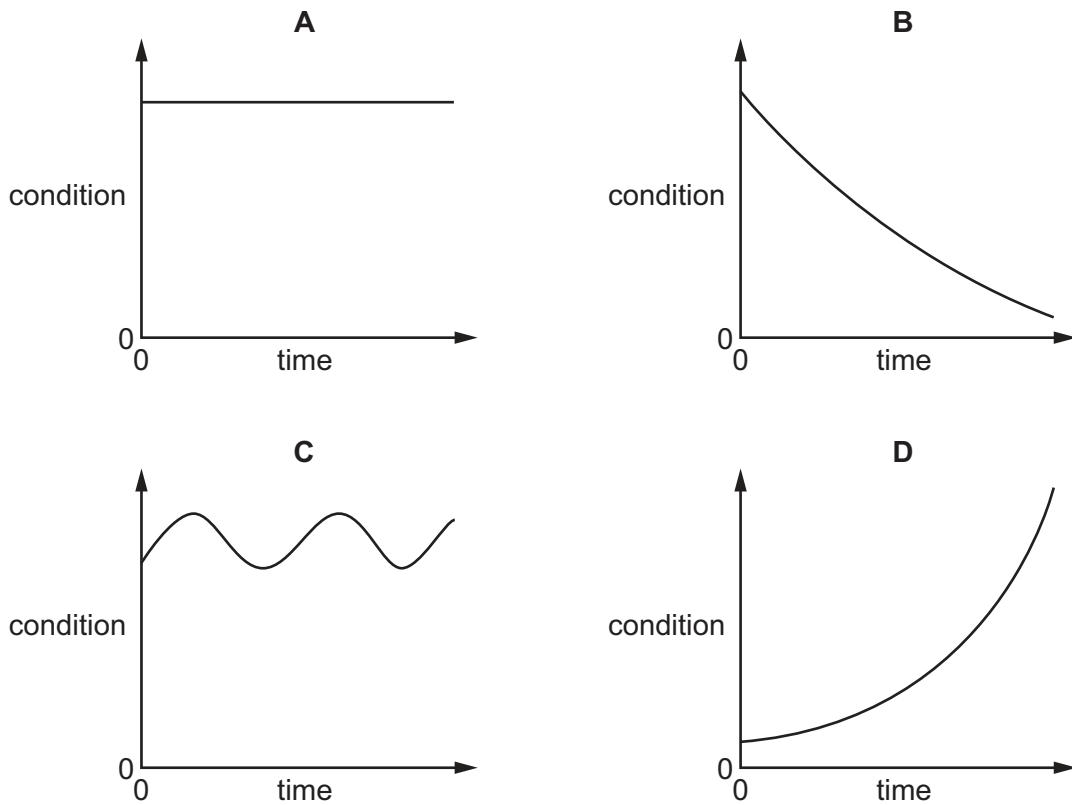

22 The diagram shows a section through part of the skin.

Which structure will produce moisture that will evaporate from the surface of the body to help reduce body temperature?

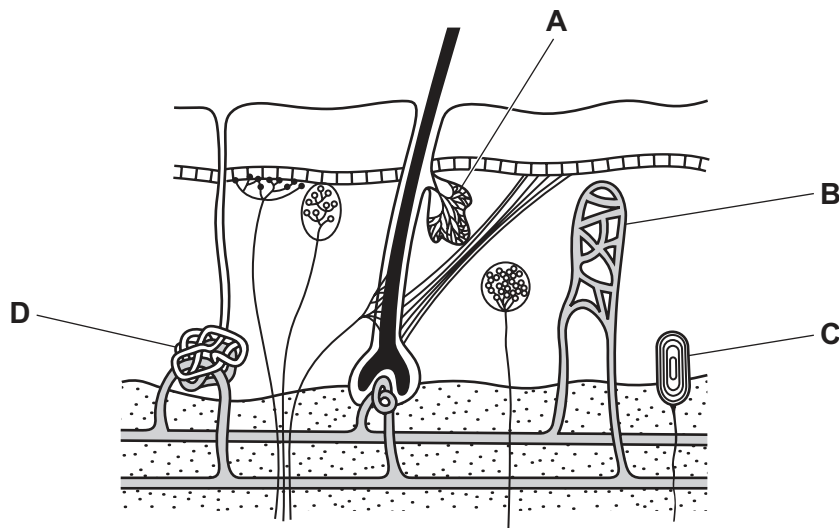

23 The diagram shows a section through a human brain.

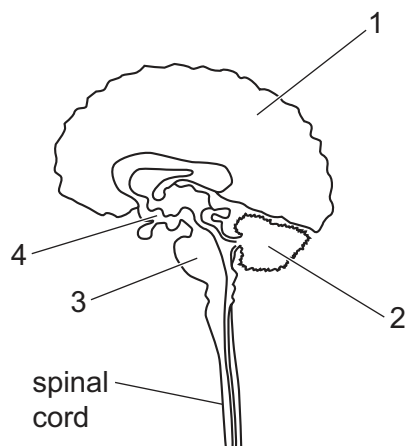

Which row shows the areas and their functions when a person is riding a bicycle up a long, steep hill?

| | area 1 | area 2 | area 3 | area 4 |
|----------|-----------------------------|-------------------------|-----------------------------|-----------------------------|
| A | balance | thinking about the task | regulating heart rate | regulating body temperature |
| B | thinking about the task | balance | regulating body temperature | controlling leg movements |
| C | regulating body temperature | thinking about the task | controlling leg movements | balance |
| D | thinking about the task | balance | regulating heart rate | regulating body temperature |

24 The diagram shows a vertical section of the human eye.

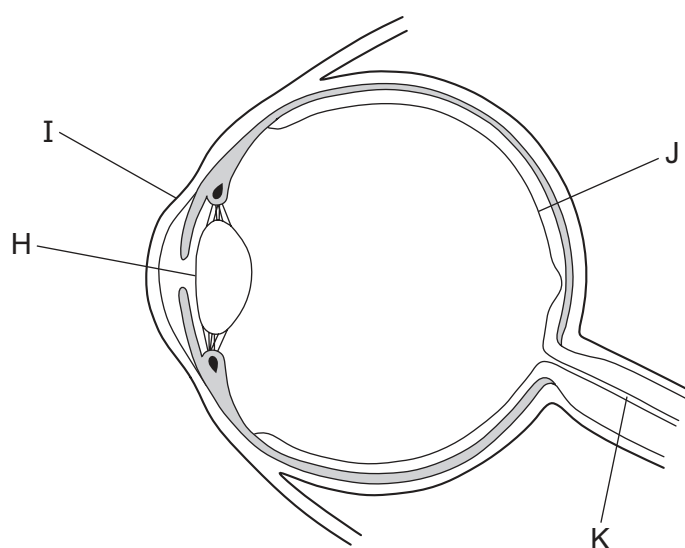

Which parts help bend light rays to form a focused image on the retina?

- A** H and I **B** I and K **C** I and J **D** H and K

- 25 In a person with diabetes mellitus, how do the concentrations of glucose in the blood and in the urine differ from those of a person without this condition?

| | concentration of glucose in blood | concentration of glucose in urine |
|----------|-----------------------------------|-----------------------------------|
| A | higher | higher |
| B | higher | same |
| C | same | lower |
| D | lower | lower |

- 26 The diagram represents the muscles and bones at the elbow joint.

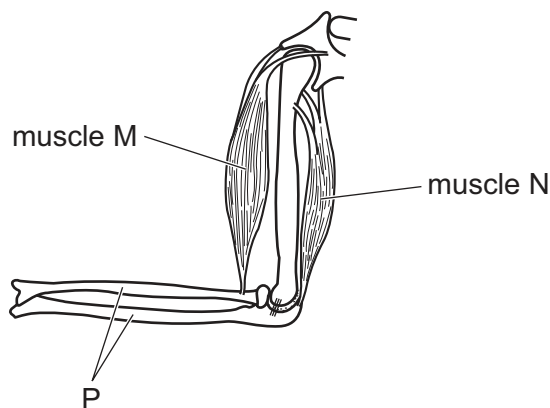

Which actions would raise the bones labelled P?

| | muscle M | muscle N |
|----------|-----------|-----------|
| A | contracts | contracts |
| B | contracts | relaxes |
| C | relaxes | relaxes |
| D | relaxes | contracts |

- 27 Which condition is associated with women who smoke heavily during pregnancy?
- A** Cigarette tar may cause cancer in the developing fetus.
 - B** Smoke particles may begin to block the lungs of the fetus.
 - C** The baby has a risk of being born with emphysema.
 - D** The baby has a risk of being underweight at birth.

28 Which row shows some structural features of three groups of microorganisms?

| | viruses | | bacteria | | fungi | |
|----------|---------|-----------|----------|-----------|---------|-----------|
| | nucleus | cell wall | nucleus | cell wall | nucleus | cell wall |
| A | ✓ | ✓ | ✓ | ✓ | ✓ | ✓ |
| B | x | ✓ | x | ✓ | x | ✓ |
| C | x | x | x | ✓ | ✓ | ✓ |
| D | ✓ | x | ✓ | x | ✓ | ✓ |

key

✓ = yes

x = no

29 The graph shows how the rate of penicillin production from the fungus *Penicillium* varies with temperature at two different oxygen concentrations.

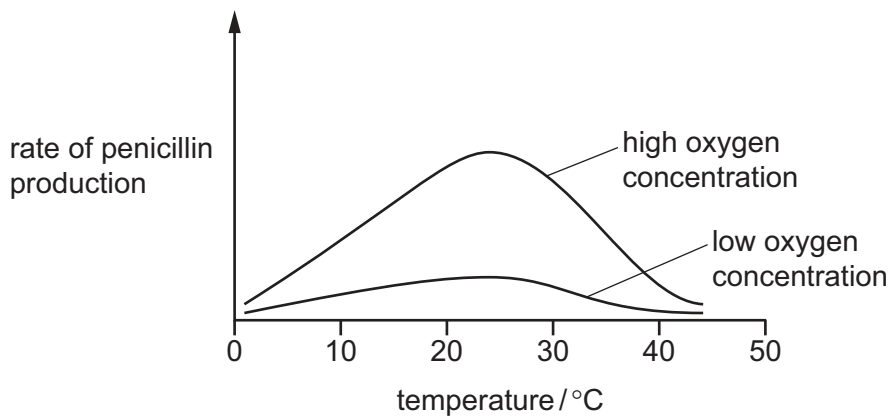

What can be deduced from the graph?

- 1 The fungus *Penicillium* respire aerobically.
- 2 The fungus *Penicillium* respire anaerobically.
- 3 The optimum temperature for penicillin production is approximately 24 °C.

A 1, 2 and 3 **B** 1 and 2 only **C** 1 and 3 only **D** 2 and 3 only

30 Which process significantly increases the amount of carbon dioxide in the air?

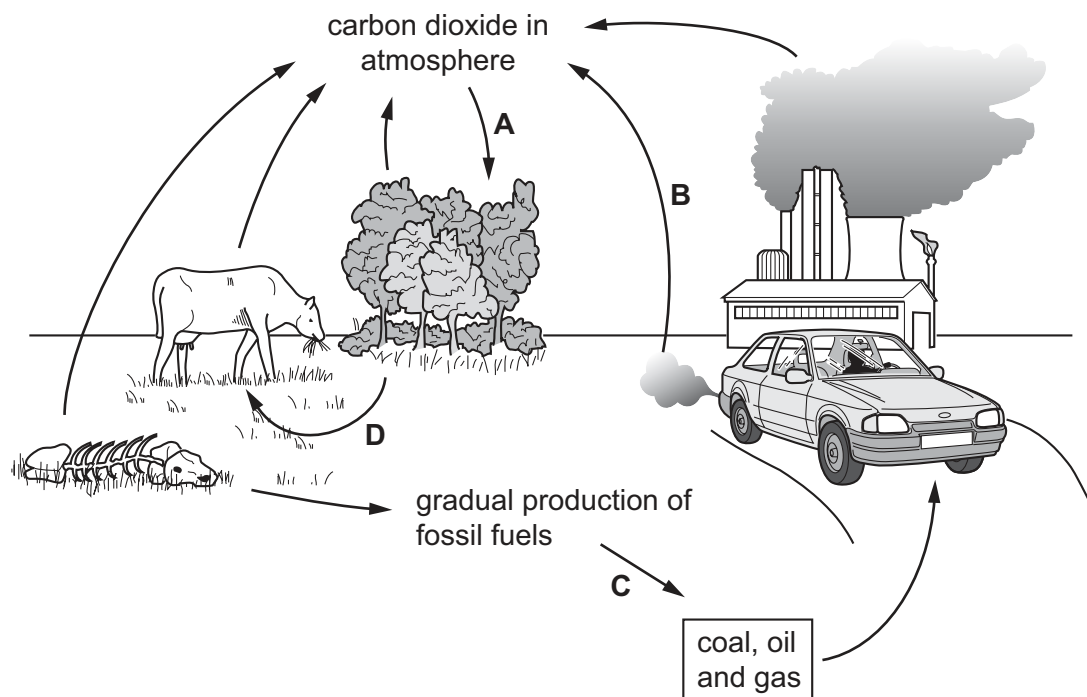

31 What would be the most effective way to reduce the number of cases of malaria in an area with very limited medical facilities?

- A a programme to encourage people to take much more exercise
- B the drainage of all areas of stagnant water
- C the early treatment of malarial patients with antibiotics
- D an improved diet to increase resistance to mosquito bites

32 Sewage is released into a river.

Which curve represents the oxygen concentration in the river?

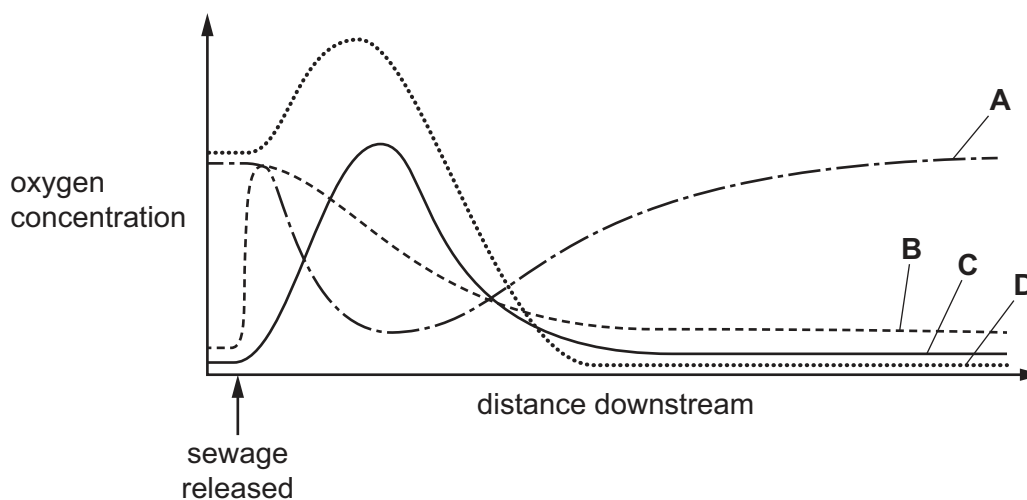

33 The diagram shows the life cycle of a flowering plant.

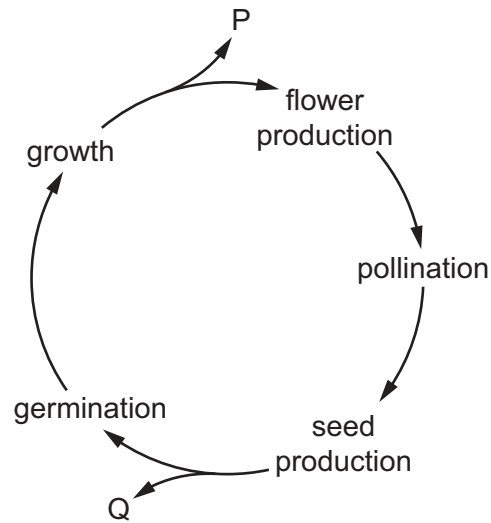

Small pieces are cut from the plant at stage P in the cycle, placed in nutrient jelly, and allowed to grow into new plants. New plants are also grown from seeds produced at stage Q in the cycle.

Which type of reproduction has taken place to produce each of the plants that develop?

| | plants developing from P | plants developing from seeds |
|----------|--------------------------|------------------------------|
| A | asexual | sexual |
| B | asexual | asexual |
| C | sexual | asexual |
| D | sexual | sexual |

34 What are the female parts of a flower?

- A** anthers
- B** carpels
- C** petals
- D** sepals

35 How are sperm cells different from egg cells in size and in number?

| | size of sperm cells | number of sperm cells |
|----------|---------------------|-----------------------|
| A | larger | fewer |
| B | larger | more |
| C | smaller | fewer |
| D | smaller | more |

36 Which two hormones are both produced in the female reproductive system?

- A FSH and LH
- B LH and oestrogen
- C oestrogen and progesterone
- D progesterone and FSH

37 Which statements are correct?

- 1 Each chromosome consists of one large molecule of DNA.
- 2 Each chromosome contains many genes.
- 3 Alleles are alternative versions of genes.

- A 1, 2 and 3 B 2 and 3 only C 2 only D 3 only

38 The diagram shows a family tree in which hereditary night-blindness occurs.

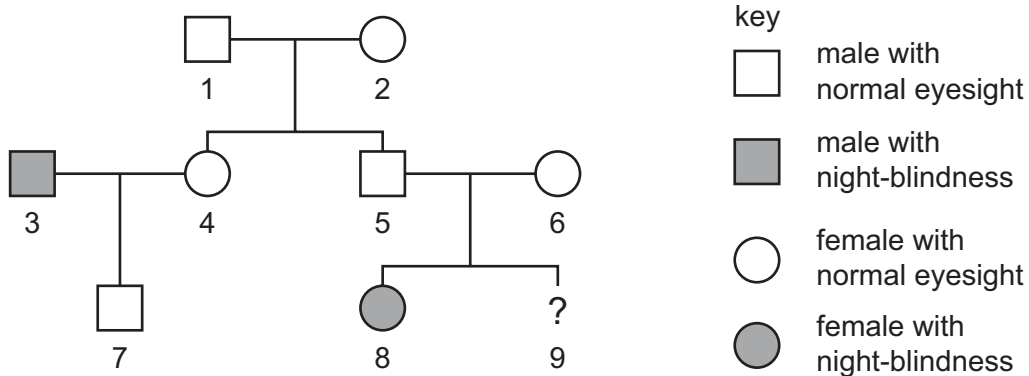

What is the chance that the unborn child, 9, will be a male with night-blindness?

- A 1 in 2 B 1 in 4 C 1 in 8 D 3 in 4

39 Which statements about natural selection are correct?

- 1 It can cause gene mutations to occur.
- 2 It can lead to the extinction of an existing species.
- 3 It occurs when farmers choose their best animals for breeding the next generation.

- A 1 only B 2 only C 3 only D 1, 2 and 3

40 The table shows statements about genetic engineering.

Which row correctly marks the statements as true or false?

| | A gene selected for transfer controls the production of many proteins. | Enzymes are used to cut out genes for transfer. | Genes can be transferred between cells of different species. | Genetic engineering is the artificial production of genes. | Human proteins can be produced by inserting genes into viral DNA. |
|----------|--|---|--|--|---|
| A | ✓ | x | x | ✓ | x |
| B | x | ✓ | ✓ | x | x |
| C | x | ✓ | ✓ | x | ✓ |
| D | ✓ | x | x | ✓ | ✓ |

key

✓ = true

x = false

BLANK PAGE

Permission to reproduce items where third-party owned material protected by copyright is included has been sought and cleared where possible. Every reasonable effort has been made by the publisher (UCLES) to trace copyright holders, but if any items requiring clearance have unwittingly been included, the publisher will be pleased to make amends at the earliest possible opportunity.

To avoid the issue of disclosure of answer-related information to candidates, all copyright acknowledgements are reproduced online in the Cambridge Assessment International Education Copyright Acknowledgements Booklet. This is produced for each series of examinations and is freely available to download at www.cambridgeinternational.org after the live examination series.

Cambridge Assessment International Education is part of the Cambridge Assessment Group. Cambridge Assessment is the brand name of the University of Cambridge Local Examinations Syndicate (UCLES), which itself is a department of the University of Cambridge.